

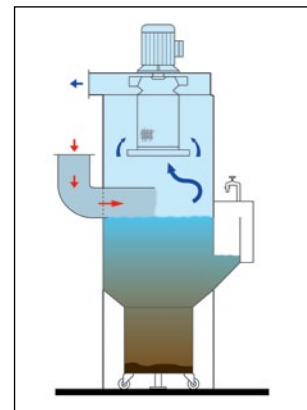

**Separation of combustible, explosive,
humid and adhesive dusts**



Compact wet scrubber VDN-E with detachable disposal bin

Function

For combustible, explosive, humid and adhesive dusts

Venturi wet scrubber models are used for the separation of substances that cannot normally be separated or are difficult to separate in dry operat-

ing systems. Keller high-performance separators inject water into the airflow as the basic concept of the Venturi principle. These multipurpose

units can be utilized in almost all sectors of industry.

Function

A capturing system collects the air pollutants at the source and conveys them via a ductwork system to the dirty air inlet of the separator to the spraying zone. At the narrowest point, water is injected into the airflow. A homogenous water curtain is created which moistens the dust particles. Heavy rotation in the separator housing separates the water

drops from the airflow using centrifugal forces. The purified air is exhausted via the fan and pushed into the exhaust air or return air system by means of a silencer. The separated dust sediments or floats on the water surface and is discharged by the disposal system.

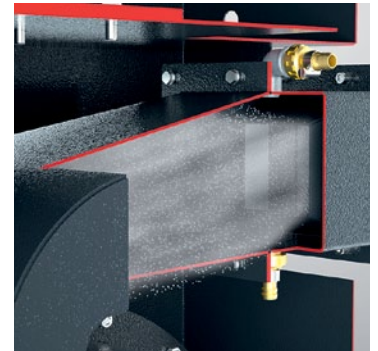

Graph: In the spraying zone is created a dense water curtain

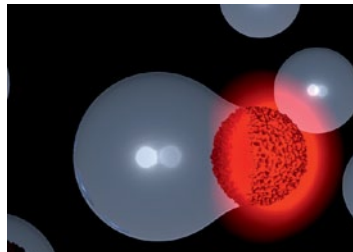

Graph: The drops of the water curtain collect pollutants, glowing particles are extinguished.



Main nozzle of a VDN-TA

Applications

- During grinding, polishing or other machining processes where glowing embers or hot dust particles may be created.
- Blasting, grinding and polishing of light metals (aluminum and magnesium alloys) whose dusts are combustible and explosive.
- Die-casting or other processes where dust and coolant fumes or mist are released.
- Moist and/or adhesive dust created in foundries and during the manufacture of ceramics or glass.
- Fumes containing dust from driers, coolants and extruders in the chemical and plastics industry.
- Press fumes released in the production of particle board and engineered wood products.

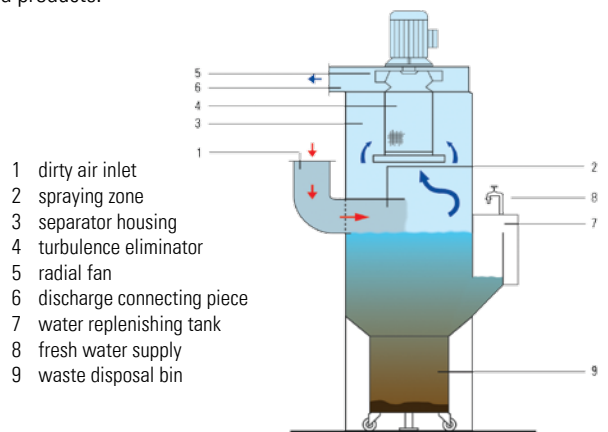

Compact wet scrubber VDN-E with detachable disposal bin

Open and closed systems

The VDN series is available as a closed or open system. The „closed system“ shall be chosen with well sedimenting materials. The water level in the water basin is regulated in such a way that the water surface is located directly at the perforated edge of the Venturi nozzle. By this is water in the separator dragged upwards and atomized. The advantages of this solution are of economic manner since a water pump can be omitted. With the „open system“ is the water supply tank separate from the nozzle area thereby creating an „open system“. Floating particles like for

example sludge or oil can be manually skimmed off, flushed away through the diverter or discharged with a scraper. With an open system shall the Venturi nozzle be fed with circulating water by a pump. The recirculation is accomplished by return ductwork for contaminated water, with the installation height determined by the low pressure in the system. Besides the Venturi nozzle, additional nozzles adjacent to the collection point can also be installed, so that the ductwork can be flushed and any deposits are minimized. Water spraying occurs both for the open and

the closed system inside the nozzle by diffused air. Reductions in the upstream water pressure are not possible for either model to prevent clogging in the narrowest point (e. g. inside a hollow shaft nozzle or full shaft nozzle).

Ductwork rinsing to prevent caking and fires

Certain processes such as hardening or plastics extrusion can create adhesive or combustible fumes and dust. To prevent caking or fires, is the dirty air rinsed with water directly in the suction ductwork behind the collec-

tion point. Fumes are partially condensed inside the ductwork by adiabatic cooling which increases separation efficiency.



Adjustment of the water level

All systems are quipped with a water balancing basin including level sensor, fresh water supply attachment and discharge diverter. If the water level falls below the required level,

the solenoid valve in the fresh water fixture is opened and additional water is supplied until the appropriate level is achieved.

Waste disposal

The physical/chemical properties of the slurry or sludge that is to be discharged defines the type of waste disposal equipment. If the ingredients are harmless, the waste water can be released into the municipal sewer system. However, federal and

local environmental regulations and instructions regarding appropriate water disposal must be observed. Harmful or toxic substances in water require special treatment.

Various series

Models

The Venturi wet scrubber compact series includes five models (VDN-E, VDN-T, VDN-TE, VDN-AS, VDN-TA). They are available in different sizes with various types of waste disposal

options. Airflows range from 2,500 m³/hr up to 28,000 m³/hr.

HydronPlus - a compact wet separator for recirculating air operation

The new HydronPlus, awarded already with the 1st prize of the Environmental Technology Award of Baden-Württemberg is especially suitable for the separation and cleaning of process exhaust air generated during brushing, blasting and grinding processes. HydronPlus combines all advantages of a wet separator with the very high separation efficiencies of a dry process while enabling

for clean air recirculation. A fan including frequency converter automatically adjusts its output to the current circumstances. Both factors contribute to the special energy efficiency of the system. With a volume flow of 1,500 cubic meters per hour is HydronPlus a flexible system which can be moved easily in case a processing station moves their position.



Keller processing table and brushing machine to HydronPlus



HydronPlus, Compact wet separator for recirculating air operation

VDN-E series with detachable disposal bin

The separated dust settles as sludge in the water and is collected in the detachable disposal bin underneath the scrubber unit. The bin must be emptied periodically during system downtimes. This disposal mode is suitable for a low volume of dust consisting of particles with good sedimentation.



Compact wet separator VDN-E with detachable disposal bin

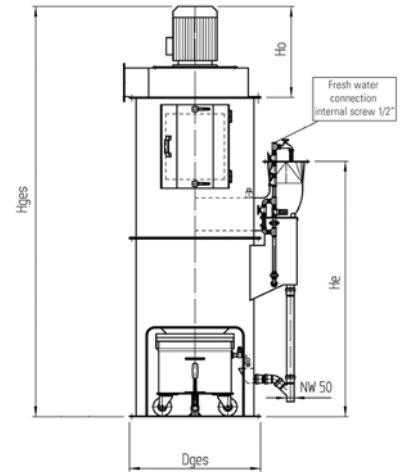

Moden series VDN-E

| VDN-E | | | | 2,5 | 3,6 | 5,6 | 8 | 12,5 |
|------------------------------|-------|-------|----|------|------|------|------|-------|
| Nominal volume flow | | V | | 2500 | 3600 | 5600 | 8000 | 12500 |
| Drive power | | kW | | 3,3 | 5,5 | 7,5 | 15,0 | 22,0 |
| Water content approx. | | liter | | 410 | 410 | 600 | 910 | 1250 |
| Diameter | Total | Dges | mm | 894 | 894 | 1095 | 1365 | 1495 |
| | Total | Hges | mm | 2614 | 2725 | 3042 | 3555 | 3980 |

Dimensions and weights are without obligation! Subject to modifications.



Overview VDN-E

VDN-T

Model series VDN-T with funnel-shaped water holding tank

The water holding tank of the VDN-T series is funnel-shaped. The separated dust collects in the hopper top which can be emptied or drained either manually by manual gate valve, or automatically by a separately con-

trolled drain valve. This system is suitable for handling low volumes of dust and water-soluble matter or coolants.



Wet scrubber VDN-T with water holding tank

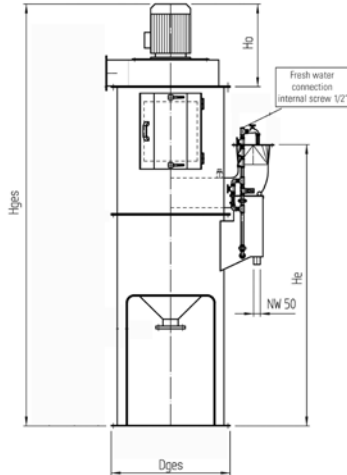

Model series VDN-T (standard)

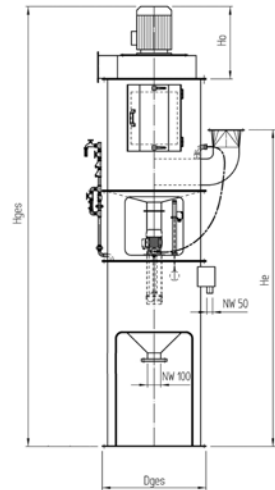

Model series VDN-T (open system)

| VDN-T | | | 3,6 | 5,6 | 8 | 12,5 | 18 | 22,4 | |
|----------------------------|-------|------|------|------|------|-------|-------|-------|------|
| Nominal volume flow | | V | 3600 | 5600 | 8000 | 12500 | 18000 | 22400 | |
| Drive power | | kW | 5,5 | 7,5 | 15 | 22 | 30 | 37 | |
| Diameter | Total | Dges | mm | 894 | 1095 | 1365 | 1495 | 1705 | 1905 |
| Height standard | Total | Hges | mm | 3170 | 3530 | 4100 | 4520 | 4910 | 5340 |
| Height open system | Total | Hges | mm | 3770 | 4130 | 4700 | 5320 | 5710 | 6140 |

Dimensions and weights are without obligation! Subject to modifications.

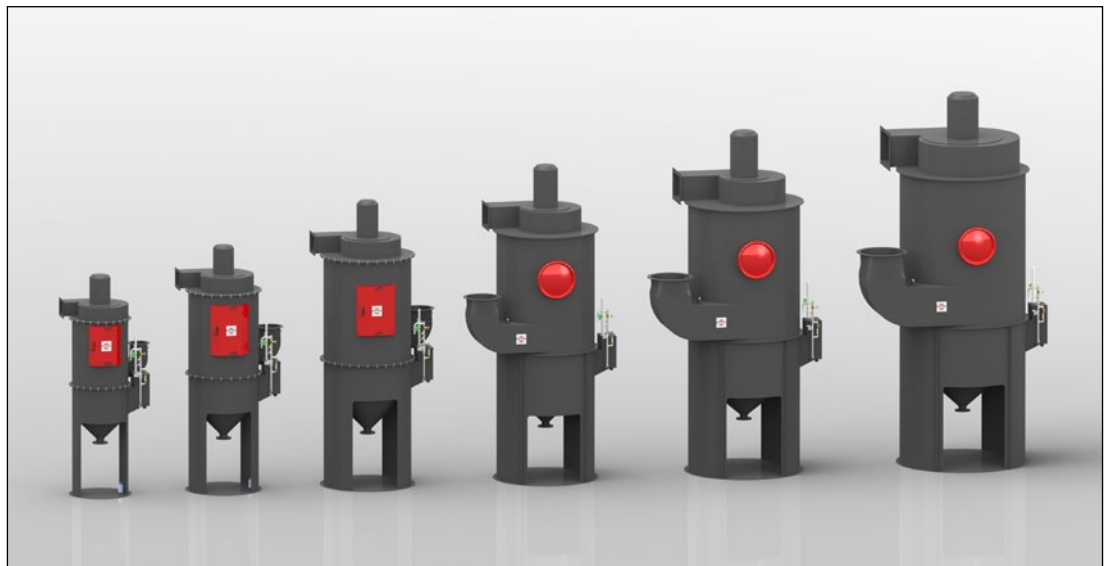

Overview VDN-T

Model series VDN-TE as a combination of disposal types „T“ or „E“

The VDN-TE is a combination of disposal types „T“ or „E“. The sludge removal can be controlled by a shut-off valve between the hopper and bucket without turning off the unit.



Wet scrubber VDN-TE

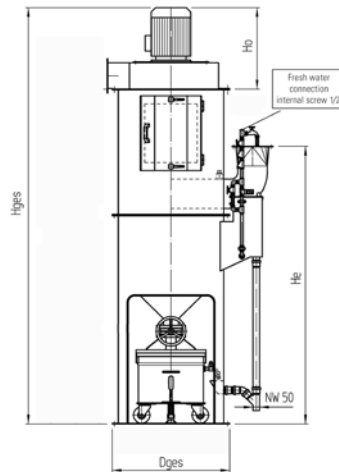

Model series VDN-TE (standard)

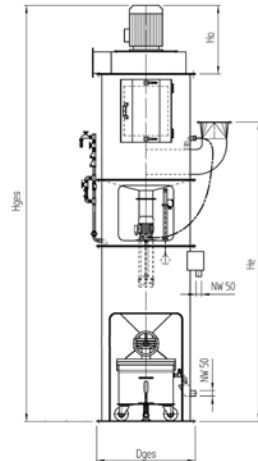

Model series VDN-TE (open system)

| VDN-TE | | | 3,6 | 5,6 | 8 | 12,5 | 18 | 22,4 | |
|----------------------------|-------|------|------|------|------|-------|-------|-------|------|
| Nominal volume flow | | V | 3600 | 5600 | 8000 | 12500 | 18000 | 22400 | |
| Drive power | | kW | 5,5 | 7,5 | 15 | 22 | 30 | 37 | |
| Diameter | Total | Dges | mm | 894 | 1095 | 1365 | 1495 | 1705 | 1905 |
| Height standard | Total | Hges | mm | 3170 | 3530 | 4100 | 4520 | 4910 | 5340 |
| Height open system | Total | Hges | mm | 3770 | 4130 | 4700 | 5320 | 5710 | 6140 |

Dimensions and weights are without obligation! Subject to modifications.



Overview VDN-TE

VDN-AS

Model series VDN-AS with automatic de-sludging device.

This unit is equipped with an automatic de-sludging device. A scraper continuously discharges the sedimented dust as sludge or at intervals. This disposal mode is suitable for

systems with a high output of dust and continuously operation (2 - 3 shifts).



Wet scrubber VDN-AS with de-sludging de

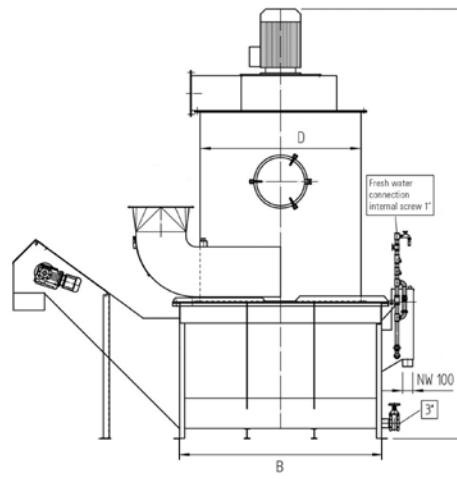

Model series VDN-AS (standard)

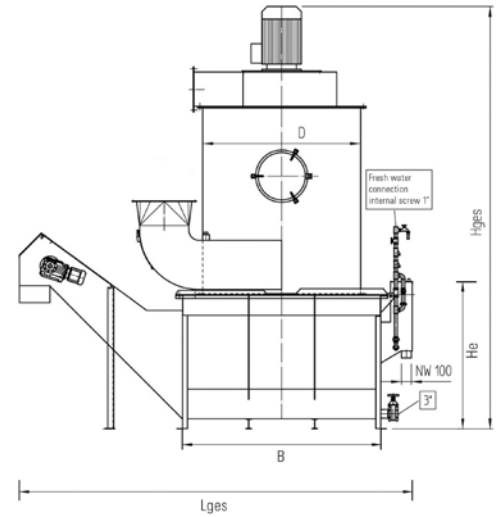

Model series VDN-AS (open system)

| VDN-AS | | | | 3,6 | 5,6 | 8 | 12,5 | 18 | 22,4 | 28 |
|----------------------------|-------|------|----|------|------|------|-------|-------|-------|-------|
| Nominal volume flow | | V | | 3600 | 5600 | 8000 | 12500 | 18000 | 22400 | 28000 |
| Drive power | | kW | | 5,5 | 7,5 | 15 | 22 | 30 | 37 | 45 |
| Diameter | Total | D | mm | 800 | 1000 | 1250 | 1400 | 1600 | 1800 | 2000 |
| Height standard | Total | Hges | mm | 2630 | 2890 | 3630 | 3980 | 4270 | 4600 | 4930 |
| Height open system | Total | Hges | mm | 3230 | 3490 | 4230 | 4780 | 5070 | 5400 | 5730 |

Dimensions and weights are without obligation! Subject to modifications.

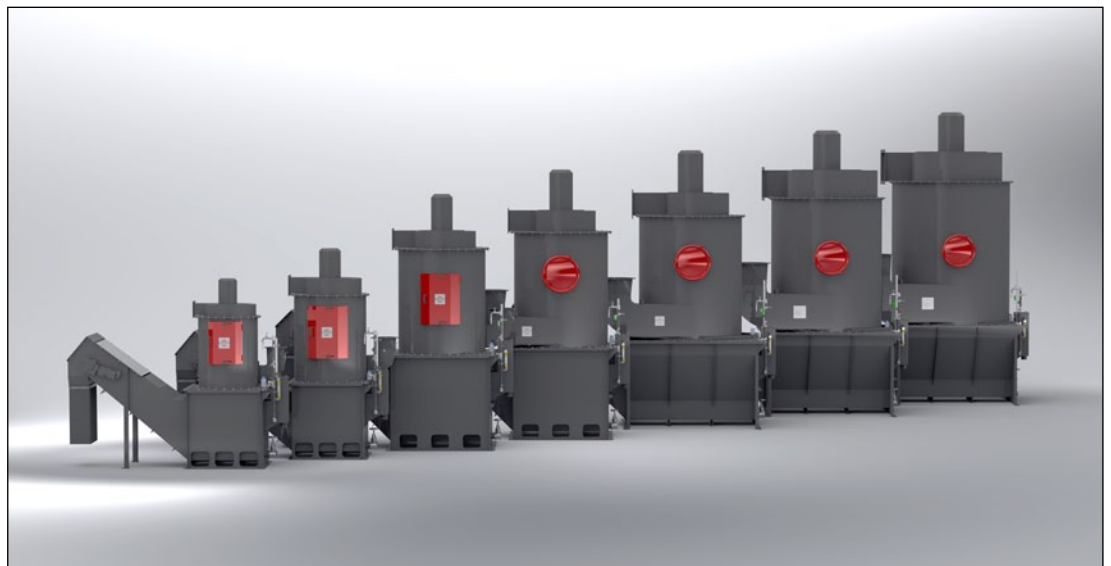

Overview VDN-AS

Model series VDN-TA as flexible system for larger airflows

Systems of the VDN-TA series are designed for larger airflows. The modular construction, i. e. Venturi nozzle, mist separator and fan of this system exist in different locations, allowing the system to be adjusted to any large airflows. External installation of one or multiple Venturi nozzles always requires an external pump to ensure adequate supply of water to the nozzles. Moreover is the fan always installed adjacent - for an easier maintenance compared to top-mounted fans.



Wet scrubber VDN-TA with sludge remover

Feasible installation of a VDN-TA system

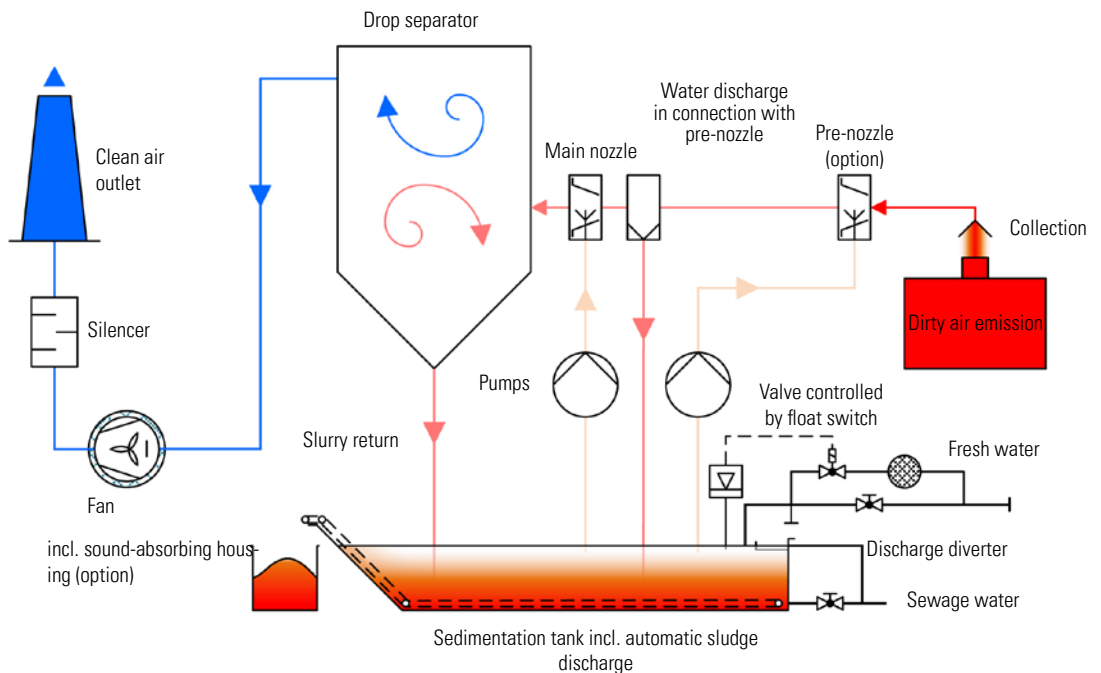

Components, i. e. nozzle, mist collector, sludge tub, and fan of the wet scrubber VDN-TA can be placed in different locations. This means flexibility for the design. It is also possible to operate several VDN-TA units with one common sludge remover.

Guidelines and Directive

Additional equipment in accordance with DGUV 109 during grinding, brushing, polishing

DGUV 109-001 or DGUV 109-002 must be adhered to in case aluminum or magnesium are separated. These directives require the following:

- Flow monitoring electronics to control the flow speed in the ductwork in order to avoid deposits.
- Low water switch to control whether the wet scrubber is provided with water for example to supply vaporized water.
- Flow monitoring (with wet scrub-

bers incl. pump, open system and VDN-TA) to control whether the pump supplies the Venturi nozzle with water.

- Locking of the wet scrubber's switch and control unit with the work machine to ensure that the wet scrubber is operating during the processing.

The VDN series is already prepared for a later retrofitting of such precautions. For new systems falling under

the DGUV 109 does Keller also offer the mentioned safety components.

42nd BImSchV: New Ordinance to avoid legionella

On 19.08.2017 came into effect the 42nd Federal Emission Control Act (42nd Emission Control Act for evaporation coolers, cooling towers and wet scrubbers). This Emission Control Act requires mandatory rules to prevent from legionella in evaporaton coolers and wet scrubbers.

The requirements of these ordinance to the design of the system are met

by Keller wet scrubbers, e. g.:

- Sample taking possible via inspection door or directly from the water basin
- Water related components can be emptied

Wet scrubbers are except from the field of application as long as they are installed in a hall and air is recirculated into the hall (such as possible

with HydronPlus). Due to the residual dust content with wet scrubbers is air in most cases vented out of doors, which is why these units belong to the field of application.

Chemical additives

Most of the known industrial dusts are extracted without any further additives by the Venturi wet scrubber. However can be required additives in some cases. Wetting agents cause a very quick wetting of the particles which enables, favors or accelerates the extraction process.

Defoaming agents avoid a heavy

foam creation to which some types of dust tend. Sedimentation auxiliaries to treat slurries let the particulate create flakes and enable an easier sedimentation. Hardness stabilising agents might come into effect (e. g. Calciumchloride). Corrosion protection agents are required for the extraction of metal and scale dust. They avoid rusting. In case the dirty air cur-

rent contains acid producers such as sulphur dioxide must be added a neutralisation agent. Dosing units for liquid additives can be obtained as accessories.

Additives

Depending on the quality of the substances to be separated can be required an add-on of one or more additives. We work closely with hebro chemie. A sample taking kit is issued alongside with each delivery in order to carry out a limitation by means of

representative dust, water, and/or sludge sample. Also delivered is Oplax-P separating agent which is sprayed on at the beginning of each cleaning and which simplifies the cleansing of adhering dust.

Following additives have proven in their worth:

Sedimentation auxiliaries

A flocculant can be added to the process water which accelerates or even ensures sedimentation with dust, un-

able to sediment.

hebro®prenol FL 115

Hardness stabilising agents

Sedimentation agents are often only effective if the process water in the wet separator shows a certain minimum hardness. Also can the hard-

ness increase in case of too high temperatures. Dosing via a dosing pump is therefore recommended.

-> **hebro®stabil 3**

Defoaming agents

Corrosion protection agents shall be added to avoid rusting, especially with acid reactions of the materials to be separated. This is mainly requested for the dust extraction of

metal and scale dust. Dosing possible by means of a pump.

-> **hebro®d-foam 2060**

Corrosion protection

Corrosion protection agents shall be added to avoid rusting, especially with acid reactions of the materials to be separated. This is mainly requested for the dust extraction of

metal and scale dust. Dosing possible by means of a pump.

-> **hebro®protect 95-103**

Biocide

A biocide is applied to prevent from propagation of bacteria (also legionella), germs, algae and resulting odor nuisance. Two various biocides shall be applied to avoid bacterial re-

sistances (see 42nd BImSchV)-> **hebrocid 79-106**

-> **hebrocid 97-152**

Separating agents

To simplify the cleansing of adherent dusts can be sprayed on a separating agent.

-> **Oplax-P**

Dosing device

Suitable dosing devices can be provided by Keller Lufttechnik upon request.

Special notes

The type of disposal of the dust-water-additive mixture shall be asked at the corresponding federal state authority (e. G. SAA i Baden-Wuerttemberg, an agency for the treatment of hazardous waste). Basically are the additives diluted and are rather un-critical.

Manufacturers of additives

Keller Luttechnik cooperates with hebro chemie.

hebro chemie
 Rostocker Str. 40
 41199 Mönchengladbach
 Phone: +49 2166 6009 0
 (Mr Ralf Totten extension 112)
 Fax: +49 2166 6009 99
 Email: info@hebro-chemie.de
 www.hebro-chemie.de



Keller Lufttechnik GmbH + Co. KG
Neue Weilheimer Str. 30
73230 Kirchheim unter Teck
Fon +49 7021 574-0
info@keller-lufttechnik.de
keller-lufttechnik.de